



# EVERPURE® QL3B SINGLE HEAD

FILTER HEAD EXCLUSIVELY FOR EVERPURE REPLACEMENT CARTRIDGES

QL3B Single Head: EV9259-24



## APPLICATIONS

Foodservice  
Vending  
OCS

## FEATURES • BENEFITS

Commercial quality filter head is designed exclusively to fit Everpure filter cartridges

Solid durable construction is ideal for foodservice and vending applications

Includes mounting bracket and screws

Engineered for durability, strength and longevity

Includes built-in water shut-off valve

Corrosion resistant hardware

All wetted parts have passed NSF® extraction tests

## INSTALLATION TIPS

Mounts directly onto flat surface.

Install vertically so cartridge hangs down.

Allow 2-1/2" (6.35 cm) clearance below the cartridge for easy cartridge replacement.

Flush filter by running water through filter according to cartridge instructions.

## OPERATION TIPS

Change cartridges on a regular six (6) month preventative maintenance program.

Change cartridges when capacity is reached or when pressure decreases.

Always flush the filter cartridge at time of installation and cartridge change.

# EVERPURE® QL3B SINGLE HEAD

## EV9259-24

### SPECIFICATIONS

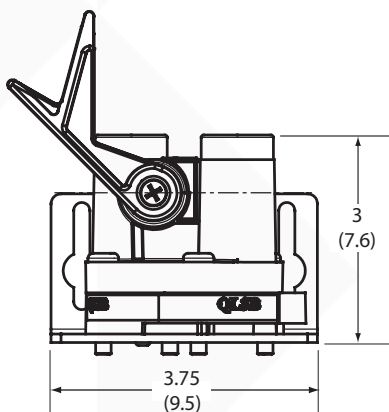

#### Overall Dimensions

3" H x 3.75" W x 3.5" D  
(7.6 cm x 9.5 cm x 8.9 cm)

#### Electrical Connection

None required

### WARRANTY

Everpure Claris water treatment systems by Pentair® (excluding replaceable elements) are covered by a limited warranty against defects in material and workmanship for a period of one year after date of purchase. Everpure replaceable elements (filter cartridges and water treatment cartridges) are covered by a limited warranty against defects in material and workmanship for a period of one year after date of purchase. See printed warranty for details. Pentair will provide a copy of the warranty upon request.



#### WATER QUALITY SYSTEMS

EVERPURE-SHURFLO WORLD HEADQUARTERS, 1040 MUIRFIELD DRIVE, HANOVER PARK, IL 60133 USA • FOODSERVICE.PENTAIR.COM  
800.942.1153 MAIN (US ONLY) • 630.307.3000 MAIN • 630.307.3030 FAX • CSEVERPURE@PENTAIR.COM EMAIL

EVERPURE-SHURFLO AUSTRALIA, 1-21 MONASH DRIVE, DANDENONG SOUTH, VIC 3175, AUSTRALIA  
011.1300.576.190 TEL • 011.61.39.562.7237 FAX • AU.EVERPURE@PENTAIR.COM EMAIL

EVERPURE-SHURFLO CHINA, 21F CLOUD 9 PLAZA, NO 1118, SHANGHAI, 200052, CHINA  
86.21.3211.4588 TEL • 86.21.3211.4580 FAX • CHINA.WATER@PENTAIR.COM EMAIL

EVERPURE-SHURFLO INDIA, GREEN BOULEVARD, B-9/A, 7TH FLOOR - TOWER B SECTOR 62, NOIDA - 201301  
91.120.419.9444 TEL • 91.120.419.9400 FAX • INDIACUSTOMER@PENTAIR.COM EMAIL

EVERPURE-SHURFLO EUROPE, PENTAIR WATER BELGIUM BVBA, INDUSTRIEPARK WOLFSTEE, TOEKOMSTLAAN, 30 B-2200 HERENTALS, BELGIUM  
+32.(0).14.283.500 TEL • +32.(0).14.283.505 FAX • SALES@EVERPURE-EUROPE.COM EMAIL

EVERPURE-SHURFLO JAPAN INC., HASHIMOTO MN BLDG. 7F, 3-25-1 HASHIMOTO, MIDORI-KU, SAGAMIHARA-SHI KANAGAWA 252-0143, JAPAN  
81.(0)42.775.3011 TEL • 81.(0)42.775.3015 FAX • INFO@EVERPURE.CO.JP EMAIL

EVERPURE-SHURFLO SOUTHEAST ASIA, SOUTHEAST ASIA, 390 HAVELOCK ROAD, #04-01, KING'S CENTRE, SINGAPORE 169662  
65.6768.5800 TEL • 65.6737.5149 FAX • CSEVERPURE@PENTAIR.COM EMAIL

All Pentair trademarks and logos are owned by Pentair, Inc. or its affiliates. All other registered and unregistered trademarks and logos are the property of their respective owners. Because we are continuously improving our products and services, Pentair reserves the right to change specifications without prior notice. Pentair is an equal opportunity employer.